

### BLOCK IDENTITY

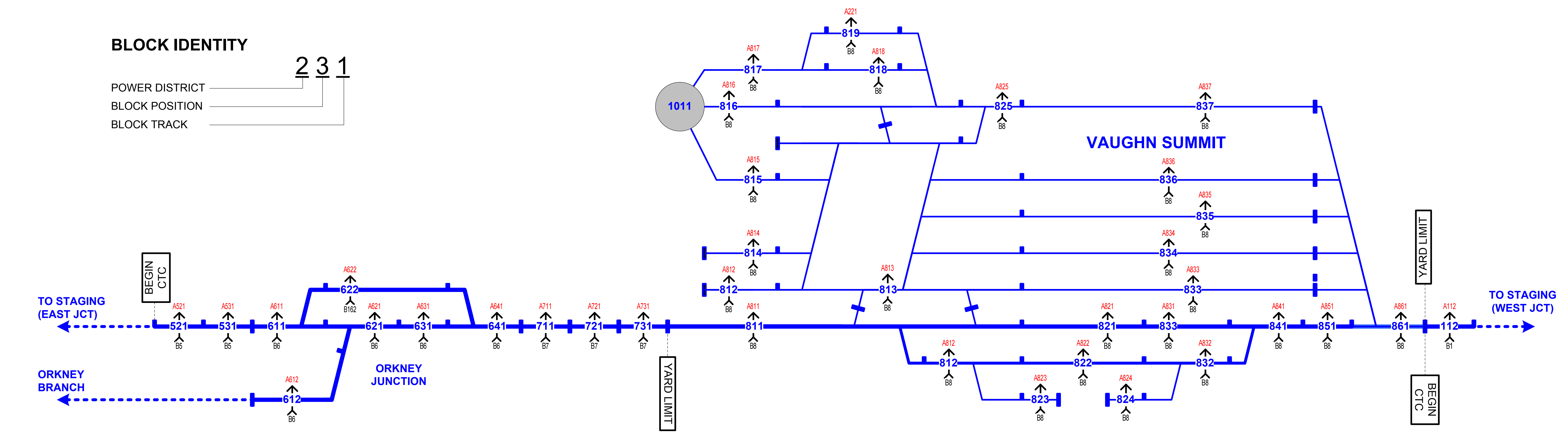

Note: Power districts are double gapped from each other. Blocks within a single power district are blocked (Rail A only) for signaling. All Rail B are common within a power district. The exception to this rule is blocks 111 and 521: these are reversing loop tracks and are therefore double gapped and controlled by auto-reversing circuits.

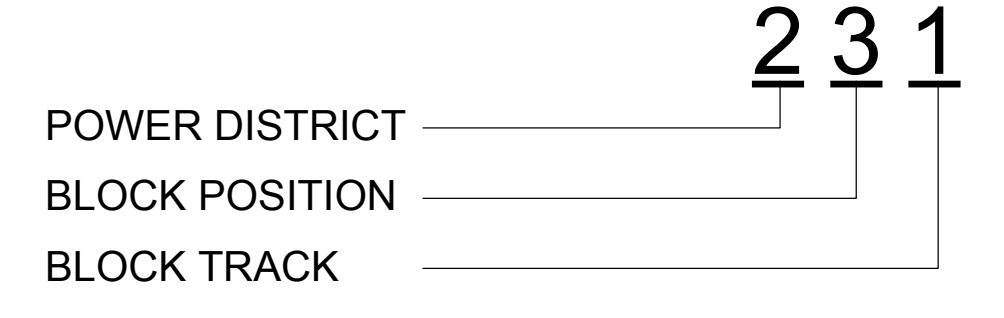